

DUAL-FLEX MARINE & INDUSTRIAL ENGINE VIBRATION ISOLATORS DF-4400 SERIES

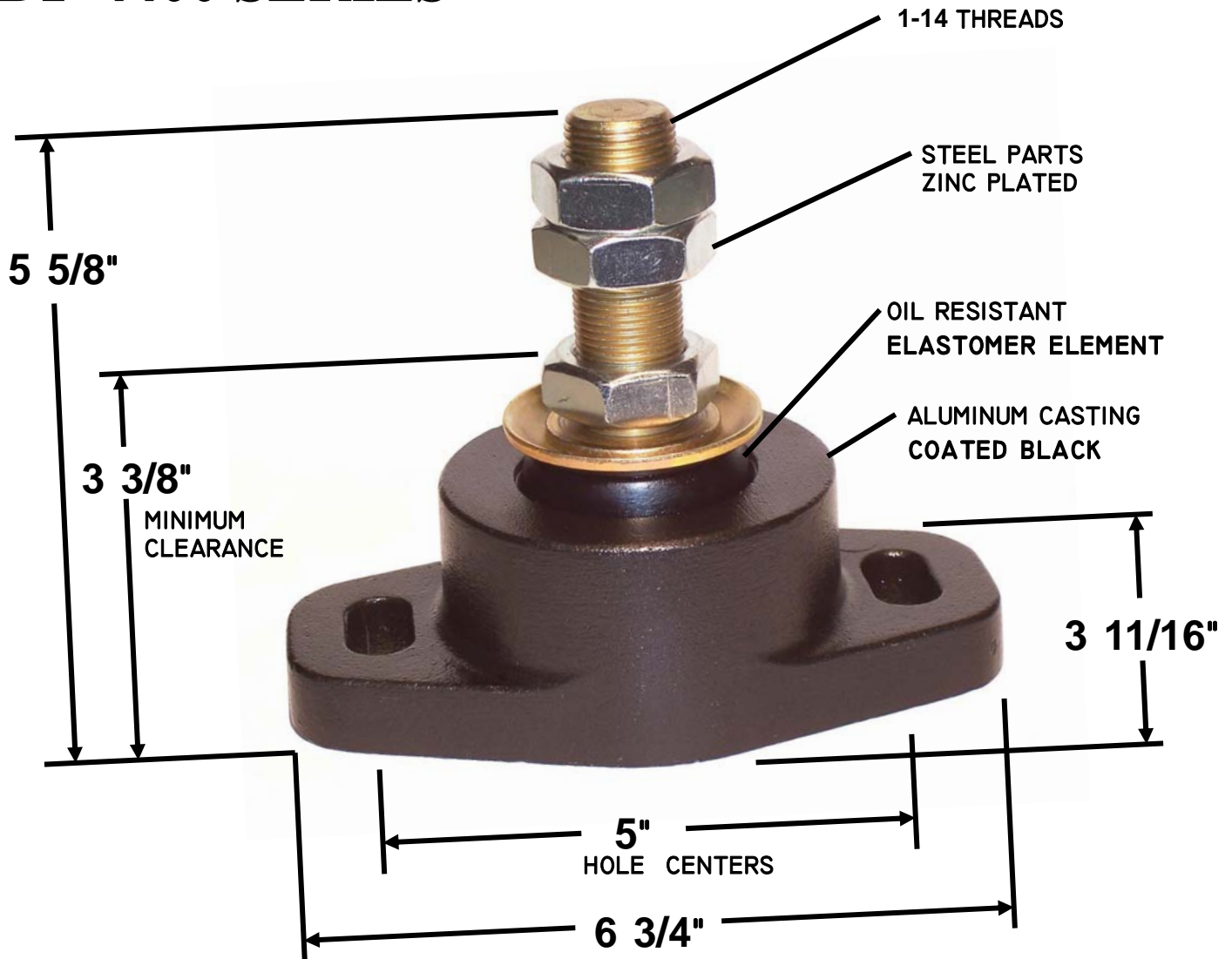

Patented
Manufactured in U.S.A.

BUSHINGS, INC.

1967 Rochester Industrial Drive
Rochester Hills, Michigan 48309-3340
Phone:(248)650-0603 Fax:(248)650-0606
www.bushingsinc.com



ISO 9001
Certified

DF-4400 SERIES

The (“Dual Flex”) DF-4400 Series of heavy duty mountings is designed principally for diesel engines in the 1,400 - 2,800 lb. range. Base casting features heavy duty aluminum alloy construction, with lip incorporated in the top of the casting to resist the upward pull of the engine - coated black to resist corrosion. Durable oil and fuel resistant elastomer element. Low profile mount - requires only 3 3/8” minimum clearance from casting base to top of leveling nut. Fail safe design - bottom pad prevents excessive impact. Easy installation with full 1” threaded stud for vertical height and slotted casting for horizontal adjustment. Mounts come complete - furnished with three nuts: leveling, locking and secondary lock. Aluminum base cast with 1/2” slotted mounting holes for 1/2” bolts or lag screws on 5” centers. All steel parts are Zinc plated for corrosion resistance. Available in four size ratings (shown below) dependant on engine/powertrain package weight.

SUGGESTED MOUNTINGS

ENGINE WEIGHTS	4 POINT MOUNTINGS
1,400 to 1,800 lbs.	DF-4405-4
1,800 to 2,200 lbs.	DF-4406-4
2,200 to 2,500 lbs.	DF-4407-4
2,500 to 2,800 lbs.	DF-4408-4

The patented Bushings, Inc. “Dual Flex” Marine Engine Mount design provides outstanding vibration isolation control across the three (longitudinal, lateral, and vertical) fields of vibratory motion. Construction of the mount gives a soft cushioning effect under normal loads, as mount loads increase across the operating range, shear resistance grows quickly providing smooth operation with a small amount of deflection.