

MARINE & INDUSTRIAL ENGINE VIBRATION ISOLATORS DF- 4420 SERIES

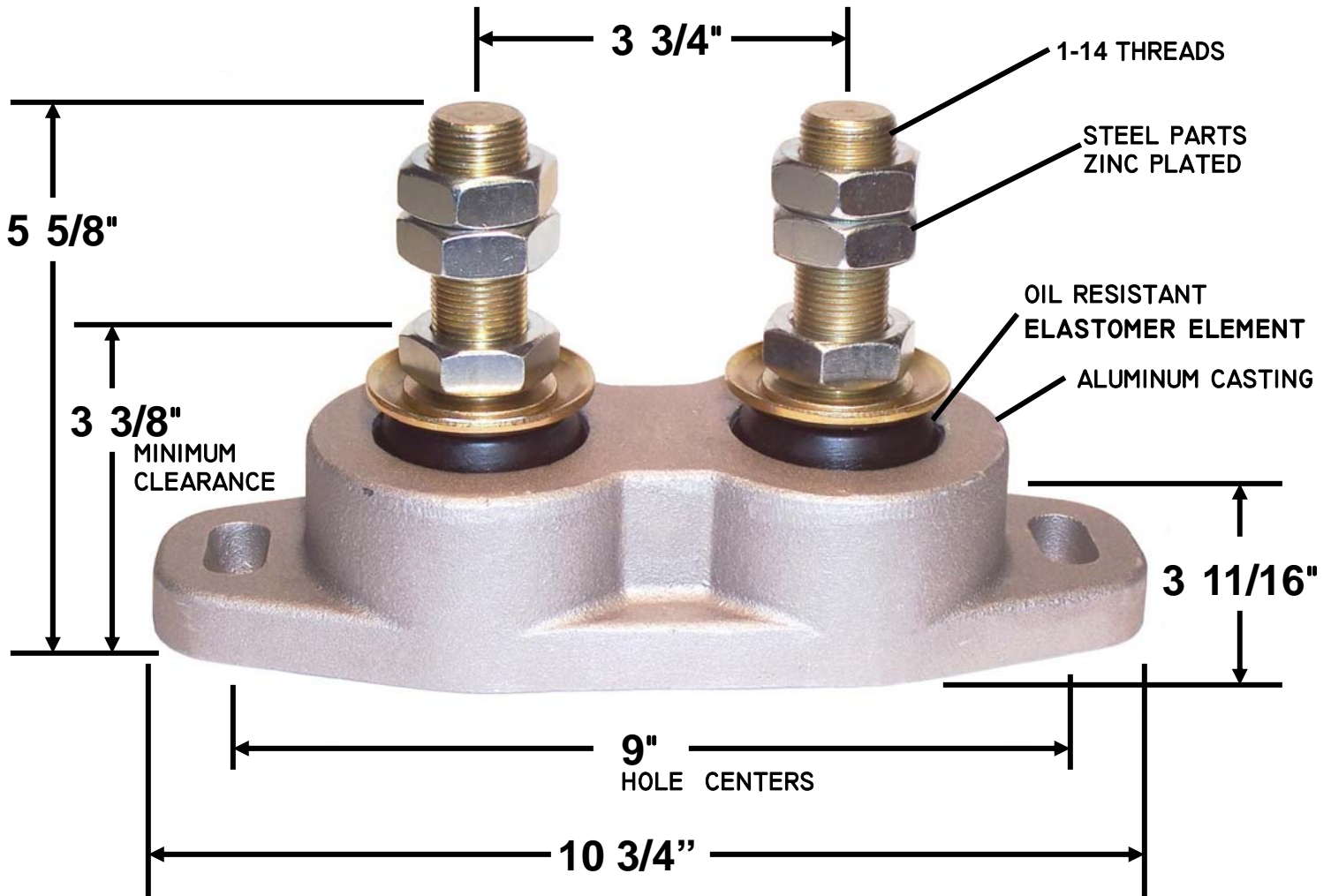

Patented
Manufactured in U.S.A.

BUSHINGS, INC.

1967 Rochester Industrial Drive
Rochester Hills, Michigan 48309-3340
Phone:(248)650-0603 Fax:(248)650-0606
www.bushingsinc.com



ISO 9001
Certified

DF-4420 SERIES

The (“Dual Flex”) DF-4420 Series of heavy duty mountings is a twin stud double mount designed principally for diesel engines in excess of 2,800 lbs. up to 5,600 lbs. in weight. These mounts are generally used on the “heavy (marine transmission) end” of the engine along with DF-4400 Series mounts on the front of the engine. Durable oil and fuel resistant elastomer element. Low profile mount - requires only 3 3/8” minimum clearance from casting base to top of leveling nut. Fail safe design - bottom pad prevents excessive impact. Easy installation with full 1” threaded studs for vertical height and slotted casting for horizontal adjustment. Mounts come complete - furnished with three nuts: leveling, locking and secondary lock. Aluminum base cast with 1/2” slotted mounting holes for 1/2” bolts or lag screws on 9” centers. All steel parts are zinc plated for corrosion resistance. Available in four size ratings (shown below) dependant on engine/powertrain package weight.

SUGGESTED MOUNTINGS

ENGINE WEIGHTS	4 POINT MOUNTINGS
2,800 to 3,600 lbs.	DF-4425-4
3,600 to 4,400 lbs.	DF-4426-4
4,400 to 5,000 lbs.	DF-4427-4
5,000 to 5,600 lbs.	DF-4428-4

The patented Bushings, Inc. “Dual Flex” Marine Engine Mount design provides outstanding vibration isolation control across the three (longitudinal, lateral, and vertical) fields of vibratory motion. Construction of the mount gives a soft cushioning effect under normal loads, as mount loads increase across the operating range, shear resistance grows quickly providing smooth operation with a small amount of deflection.